

STYKLISTE NR 51981.

INDEKS TIL STYKLISTE NR.

NO.	GENSTAND	MÆRKE	MATE-RIALE	MOJEL-MÆRKE	VÆGT
2.	Hovedluftbeholder.	1.		Købes.	
2.	Luftbeholder for Sand og Hjælpeluftbeholder.	2.		-"-	
1.	Hjælpeluftbeholder.	3.		-"-	
6.	Holder.	4.	Flussj.	#38x8 x 7620	
2.	do.	5.	"	2520	
2.	do.	6.	"	1960.	
8.	Mellelag.	7.	Bøget	Bøget	
2.	do.	8.	"	-"-	
2.	Bolt 5/8" x 60. sort.	9.			
6.	do. 5/8" x 50. -"	10.			
12.	do. 5/8" x 40. -"	11.			
20.	Møtrik. 5/8"	12.	Flussj. Best.		
20.	Fjederstive.	13.	Staal. Mayan		

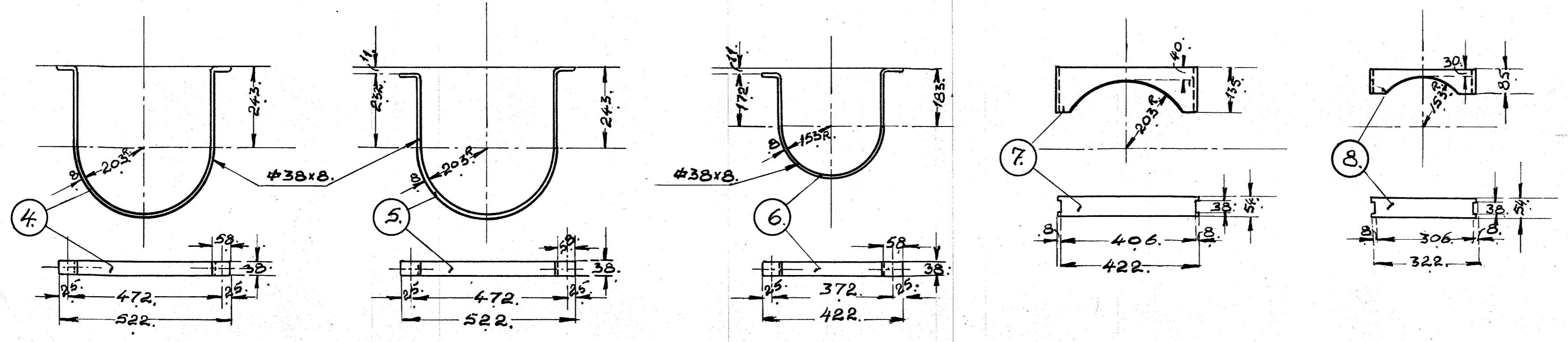
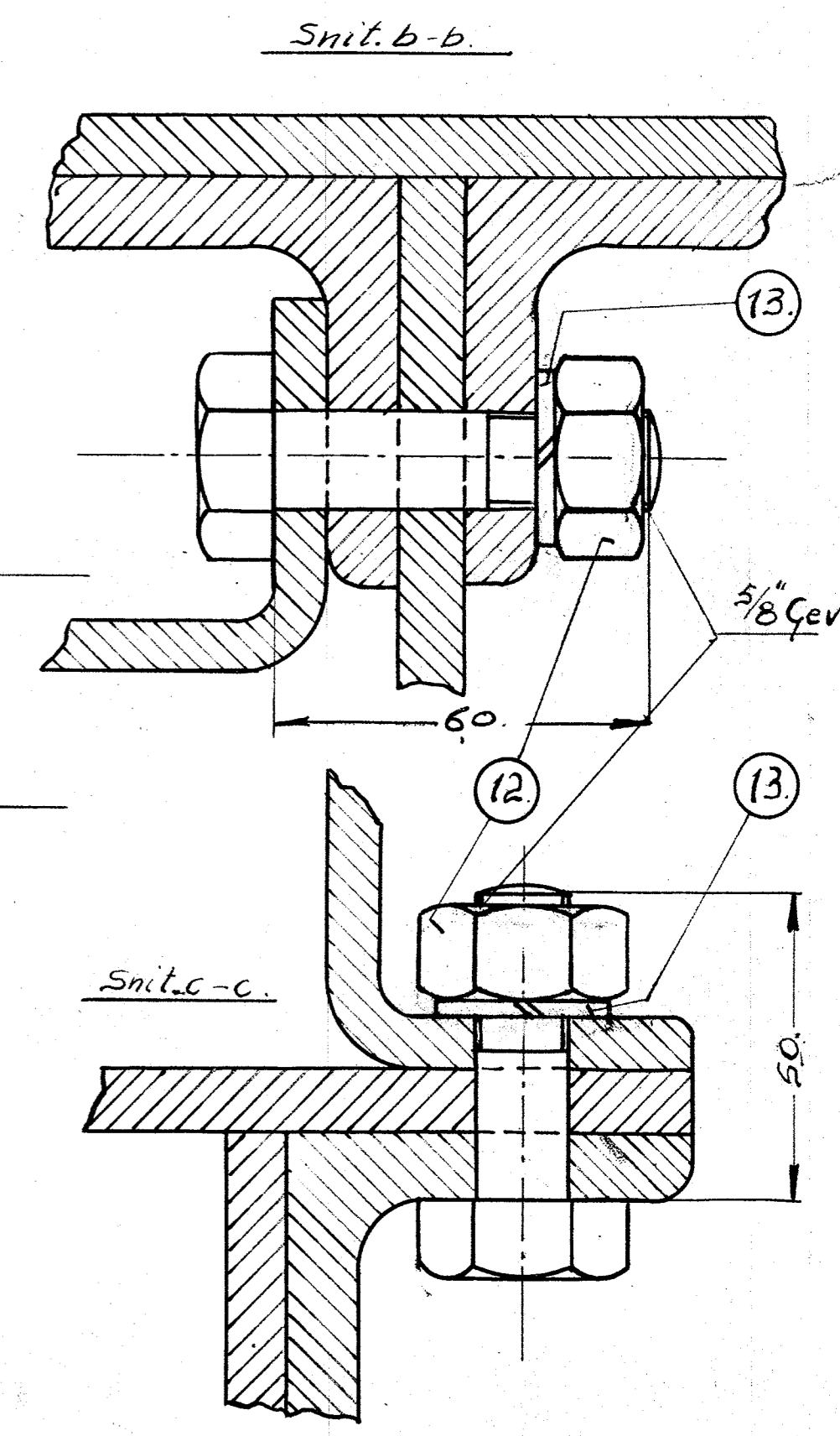
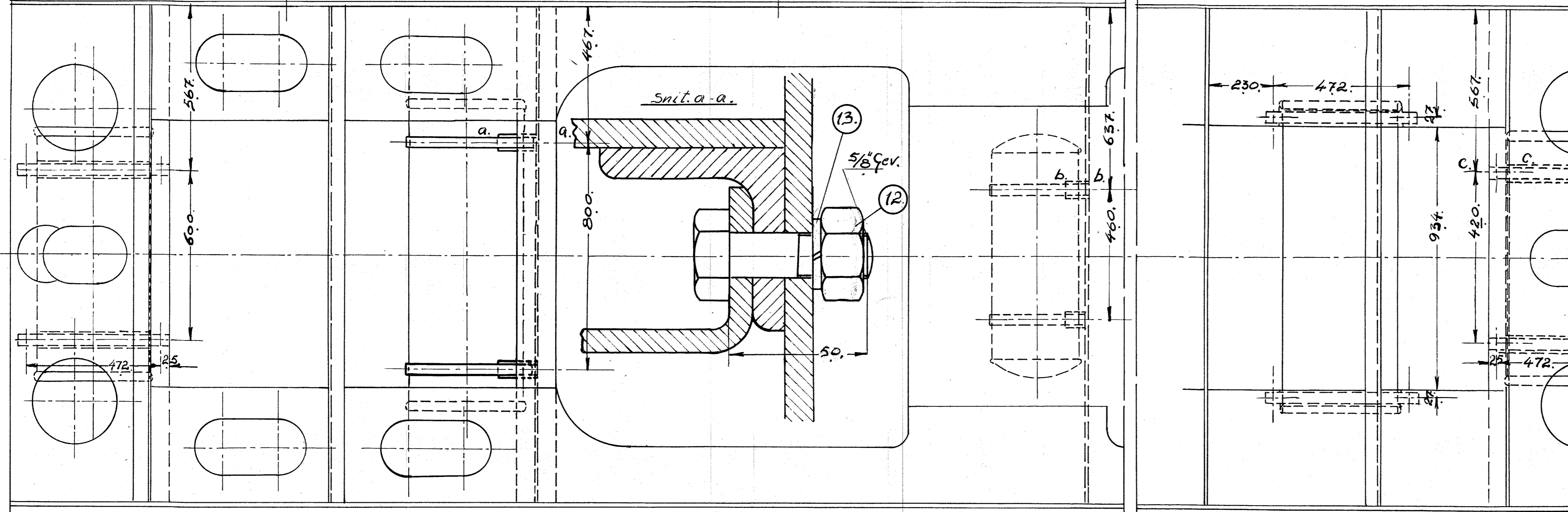
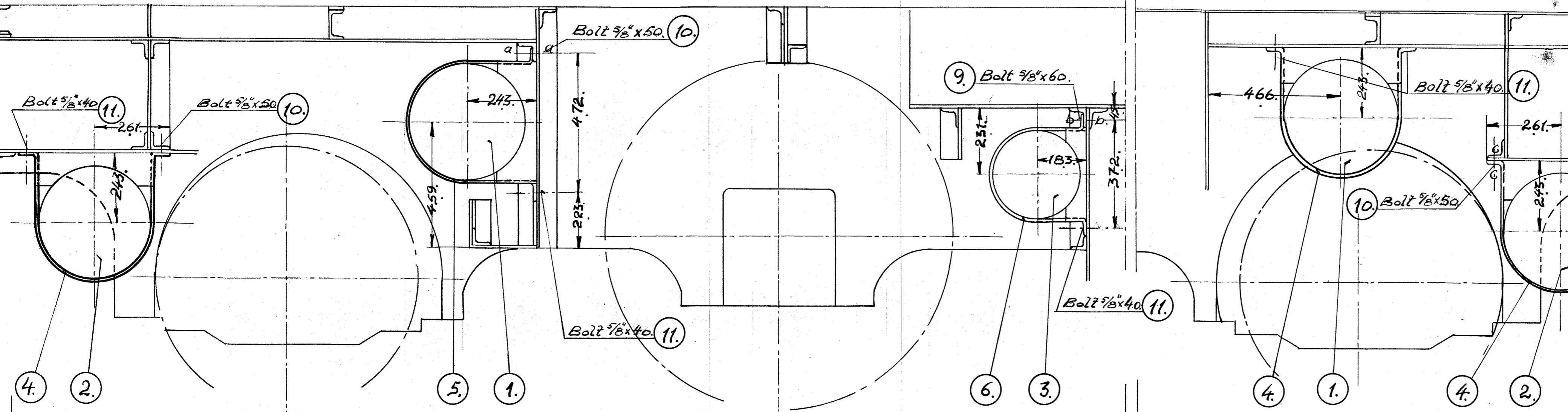

A/S FRICH'S AARHUS  
 1:10.  
 R. V. M. J.  
 ML.  
 13-9-32  
 Befæstigelse af Luftbeholdere.  
 Diesel-el-250.H. Motorloko.  
 120L-22-57